



# APPROVAL SHEET

Approval Specification	Customer's Approval Certificate
<b>TO:</b>  <b>Part No.:</b>  <b>Customer's Part No.:</b>	Please return this copy as a certification of your approval  <b>Checked &amp; Approved by:</b>  <b>Date:</b>

## BEIJING ZHONGXUN SIFANG SCIENCE & TECHNOLOGY CO.,LTD.

Tel: +86-010-58937383  
 Fax: +86-010-58937263  
 E-mail: [bjzxsf@bjzxsf.net](mailto:bjzxsf@bjzxsf.net)  
 Website: <http://www.bjzxsf.net>  
 Add: No 201, Block A. Building 3. Yongjie Beilu  
 Yongfeng high-tech industrial base  
 Haidian District Beijing city



Part No.	:	SF3240
Pages	:	6
Date	:	2014/7/8
Revision	:	1.0

<b>Prepared by:</b>	梁浩
<b>Checked by:</b>	
<b>Approved by:</b>	

**Application**

- Low-loss SAW component
- Low amplitude ripple
- Sharp rejections at both out-bands
- Usable passband 20 MHz

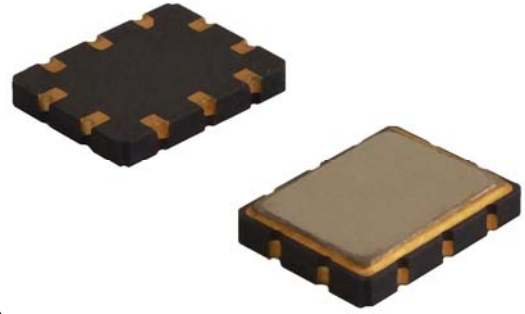

**Features**

- Ceramic Package for **Surface Mounted Technology (SMT)**
- **RoHS** compatible
- Package size 7.00x5.00x1.60mm<sup>3</sup>
- Package Code QCC12C
- **Electrostatic Sensitive Device(ESD)**

**Package Dimensions (Unit: mm)**

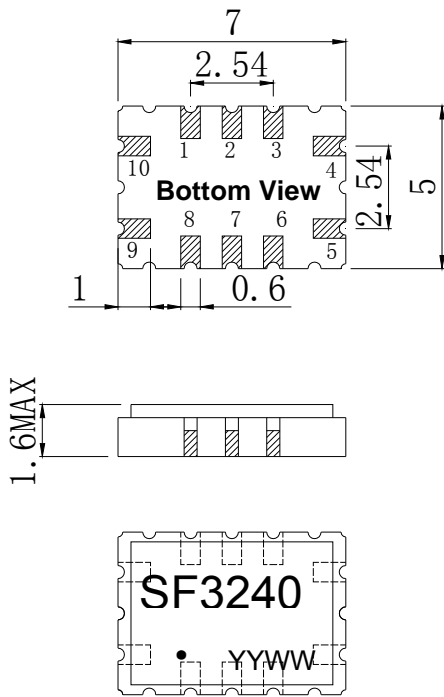

**Pin Configuration**

Pin No.	Description
9	Input
4	Output
1,2,3,5,6,7,8,10	Ground

**Marking Description**

<b>S</b>	Trademark
<b>F</b>	SAW Filter
<b>3240</b>	Part Number
●	Pin 1
<b>YYWW</b>	Year Code & Week Code

**Test Circuit(Bottom View)**

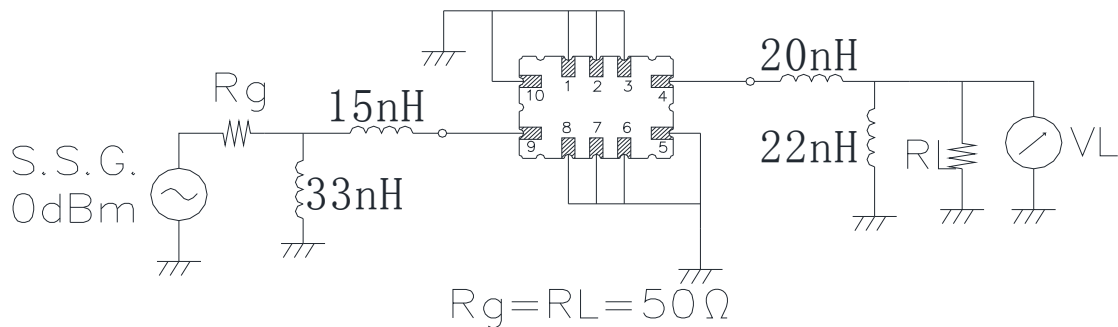

\*Fig: If the products produced in 06<sup>th</sup> week of 2012,  
The year code & week code is 1206.

**Performance****Maximum Rating**

Item		Value	Unit
DC Voltage	V <sub>DC</sub>	3	V
Operation Temperature	T	-30 ~ +60	°C
Storage Temperature	T <sub>stg</sub>	-55 ~ +85	°C
RF Power Dissipation	P	10	dBm

**Electronic Characteristics**

Test Temperature: 25°C ± 2°C

Terminating source impedance: 50Ω

Terminating load impedance: 50Ω

Item		Minimum	Typical	Maximum	Unit
Center Frequency	f <sub>c</sub>		320.0		MHz
Insertion Loss(min)	IL		10.1	15.0	dB
Amplitude Ripple	Δα		0.5	0.8	dB
0.8 dB Bandwidth	BW <sub>0.8dB</sub>	22.7	23.3		MHz
Group Delay Ripple 310.00-330.00MHz	GDR		30.0	40.0	ns
Group Delay Ripple 313.00-327.00MHz	GDR		28.0	35.0	ns
Absolute Attenuation	α				
292.00MHz		40.0	55.0		dB
302.00MHz		30.0	56.0		dB
338.00MHz		30.0	41.0		dB
348.00MHz		40.0	43.0		dB
Input VSWR 310.00-330.00MHz			2.3:1	2.5:1	/
Output VSWR 310.00-330.00MHz			2.3:1	2.5:1	/

Frequency Characteristics

Frequency Response

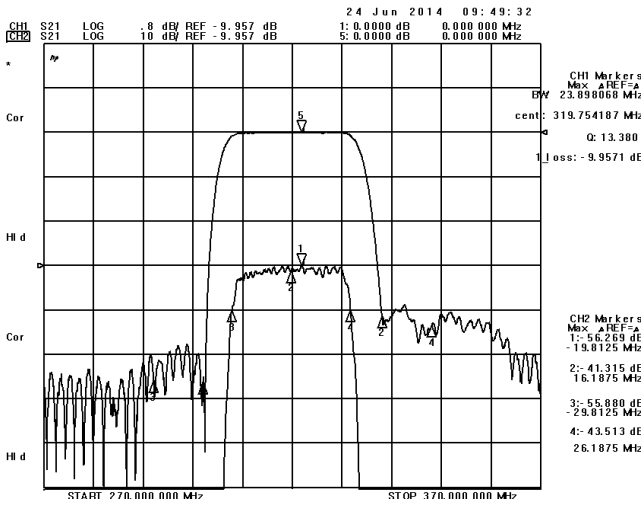

Frequency Response (wideband)

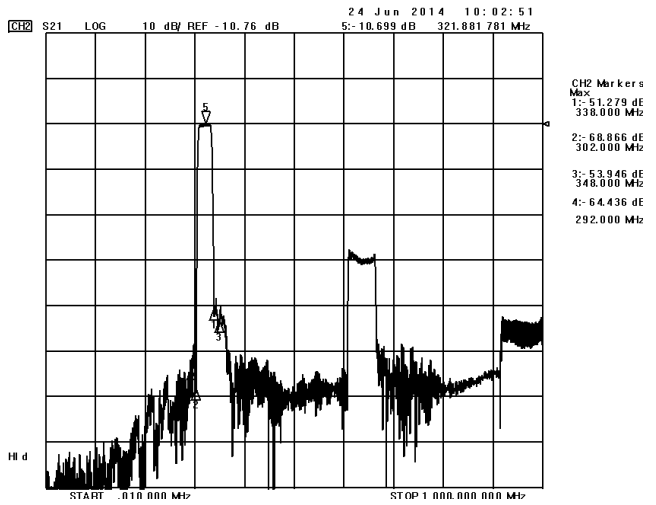

Delay Ripple & S11 VSWR

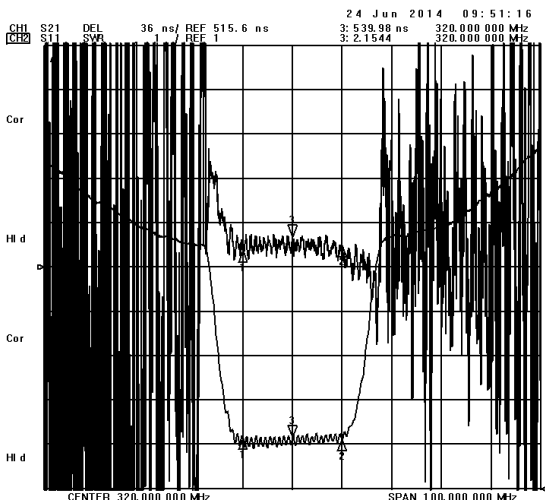

Phase Linearity & S22 VSWR

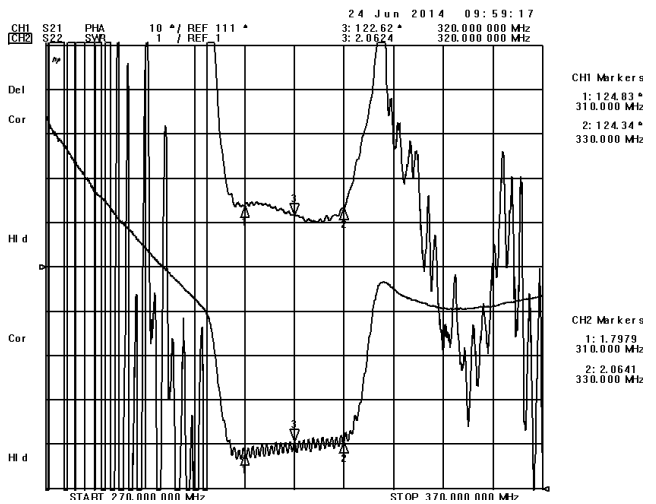

S11 Smith Chart

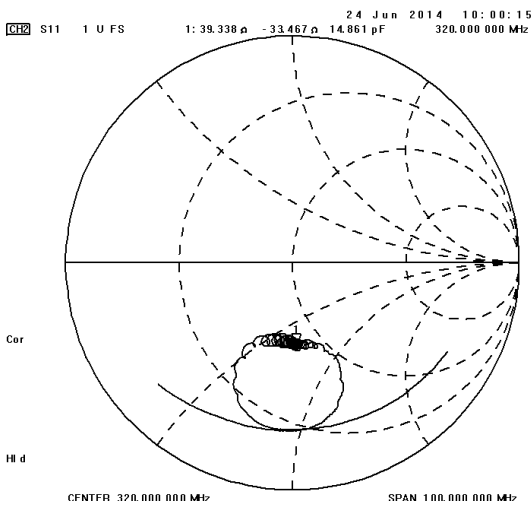

S22 Smith Chart

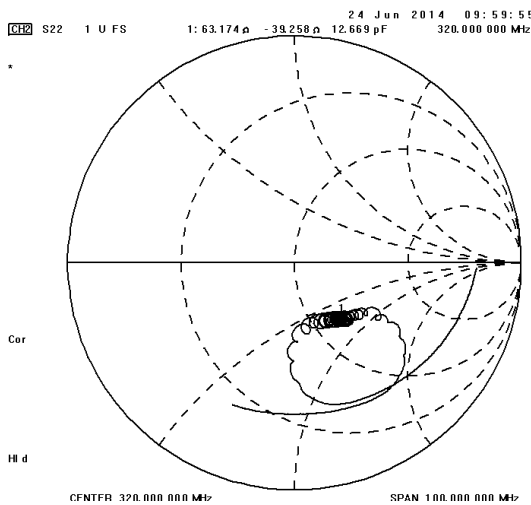



**Notes**

1. As a result of the particularity of inner structure of SAW products, it easy to be breakdown by electrostatic, so we should pay attention to **ESD protect** in the test.
2. **Static voltage** between signal load and ground may cause deterioration and destruction of the component. Please avoid static voltage.
3. **Ultrasonic cleaning** may cause deterioration and destruction of the component. Please avoid ultrasonic cleaning.
4. Only leads of component may **be soldered**. Please avoid soldering another part of component.
5. There is a close relationship between the device's performance and **matching network**. The specifications of this device are based on the test circuit shown above. L and C values may change depending on board layout. Values shown are intended as a guide only.