



# APPROVAL SHEET

| Approval Specification   | Customer's Approval Certificate   |
|--|---|
| <p><b>TO:</b></p> <p><b>Part No.:</b></p> <p><b>Customer's Part No.:</b></p> | <p>Please return this copy as a certification of your approval</p> <p><b>Checked &amp; Approved by:</b></p> <p><b>Date:</b></p> |

## BEIJING ZHONGXUN SIFANG SCIENCE & TECHNOLOGY CO.,LTD.

Tel: +86-010-58937383  
 Fax: +86-010-58937263  
 E-mail: [bjzxsf@bjzxsf.net](mailto:bjzxsf@bjzxsf.net)  
 Website: <http://www.bjzxsf.net>  
 Add: No 201, Block A. Building 3. Yongjie Beilu  
 Yongfeng high-tech industrial base  
 Haidian District Beijing city



|          |   |          |
|----------|---|----------|
| Part No. | : | SF1530   |
| Pages    | : | 6        |
| Date     | : | 2015/7/2 |
| Revision | : | 1.0      |

|                     |    |
|---------------------|----|
| <b>Prepared by:</b> | 梁浩 |
| <b>Checked by:</b>  |    |
| <b>Approved by:</b> |    |

**Application**

- Low-loss SAW component
- Low amplitude ripple
- Sharp rejections at both out-bands
- Passband 1.80MHz

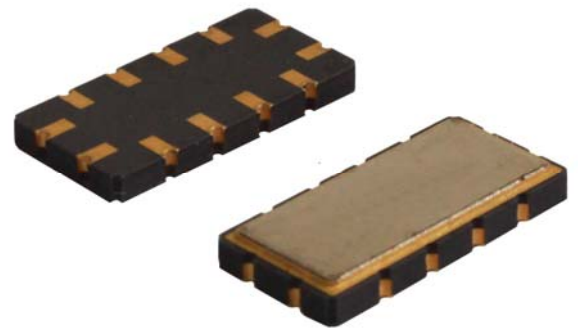

**Features**

- Ceramic Package for **Surface Mounted Technology (SMT)**
- **RoHS** compatible
- Package size 13.30x6.50x1.80mm<sup>3</sup>
- Package Code QCC12
- **Electrostatic Sensitive Device(ESD)**

**Package Dimensions (Unit: mm)**

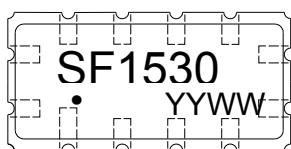
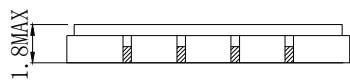
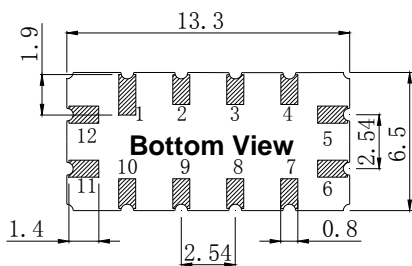

**Pin Configuration**

| Pin No.               | Description |
|-----------------------|-------------|
| 11                    | Input       |
| 5                     | Output      |
| 1,2,3,4,6,7,8,9,10,12 | Ground      |

**Marking Description**

|             |                       |
|-------------|-----------------------|
| <b>S</b>    | Trademark             |
| <b>F</b>    | SAW Filter            |
| <b>1530</b> | Part Number           |
| ●           | Pin 1                 |
| <b>YYWW</b> | Year Code & Week Code |

\*Fig: If the products produced in 06<sup>th</sup> week of 2012, The year code & week code is 1206.

**Test Circuit(Bottom View)**

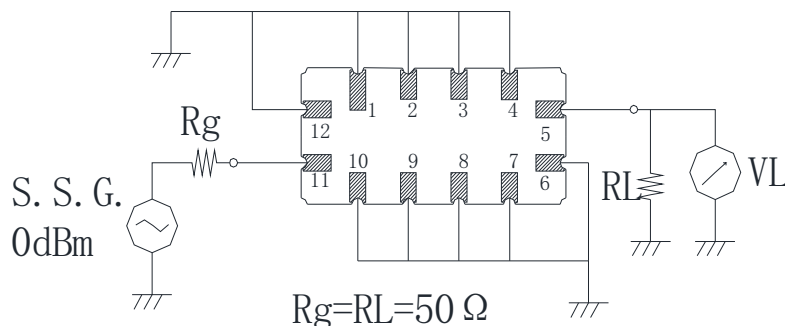

**Performance****Maximum Rating**

| Item                  |           | Value      | Unit |
|-----------------------|-----------|------------|------|
| DC Voltage            | $V_{DC}$  | 3          | V    |
| Operation Temperature | T         | -40 ~ +70  | °C   |
| Storage Temperature   | $T_{stg}$ | -55 ~ +125 | °C   |
| RF Power Dissipation  | P         | 10         | dBm  |

**Electronic Characteristics**

Test Temperature:  $25^{\circ}\text{C} \pm 2^{\circ}\text{C}$

Terminating source impedance:  $50\Omega$

Terminating load impedance:  $50\Omega$

| Item                 |                  | Minimum | Typical | Maximum | Unit |
|----------------------|------------------|---------|---------|---------|------|
| Center Frequency     | fc               |         | 163.7   |         | MHz  |
| Insertion Loss(min)  | IL               |         | 2.9     | 3.0     | dB   |
| Amplitude Ripple     | $\Delta\alpha$   |         | 0.6     | 1.0     | dB   |
| 1 dB Bandwidth       | $BW_{1dB}$       | 1.80    | 1.95    | 2.30    | MHz  |
| Absolute Attenuation | $\alpha$         |         |         |         |      |
|                      | DC-139.50MHz     | 55.0    | 60.0    |         | dB   |
|                      | 139.50-160.00MHz | 48.0    | 50.0    |         | dB   |
|                      | 167.00-251.00MHz | 48.0    | 49.0    |         | dB   |
|                      | 251.00-515.00MHz | 38.0    | 46.0    |         | dB   |

Frequency Characteristics

Frequency Response

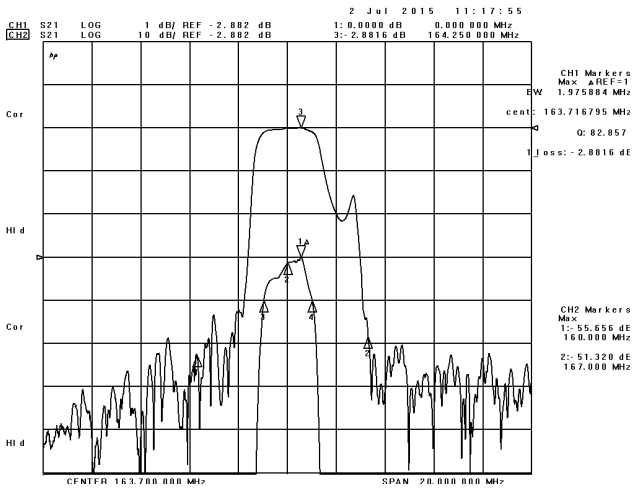

Frequency Response (wideband)

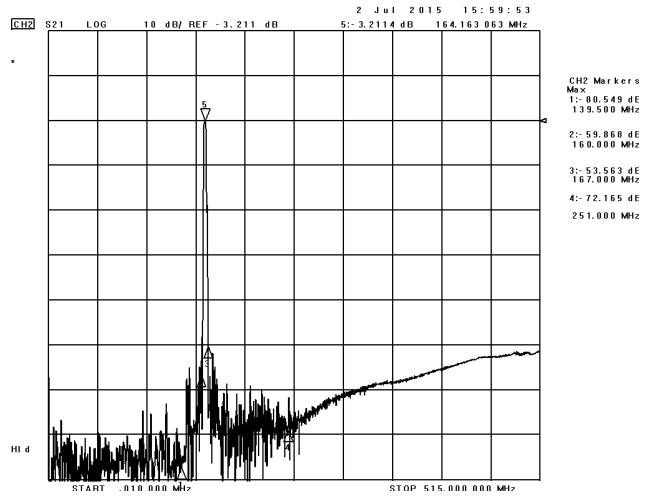

Delay Ripple & S11 VSWR

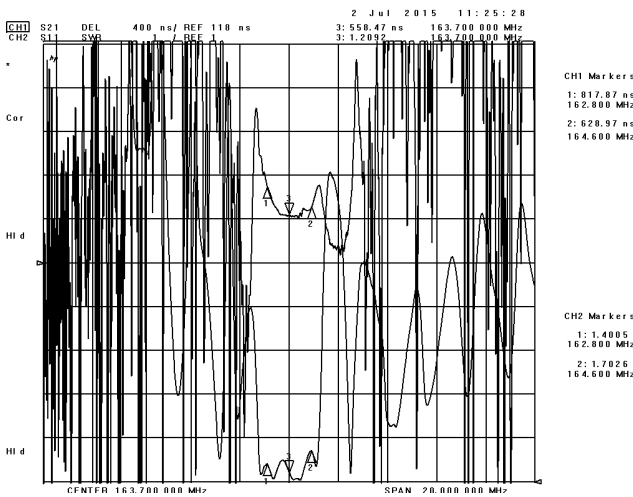

Phase Linearity & S22 VSWR

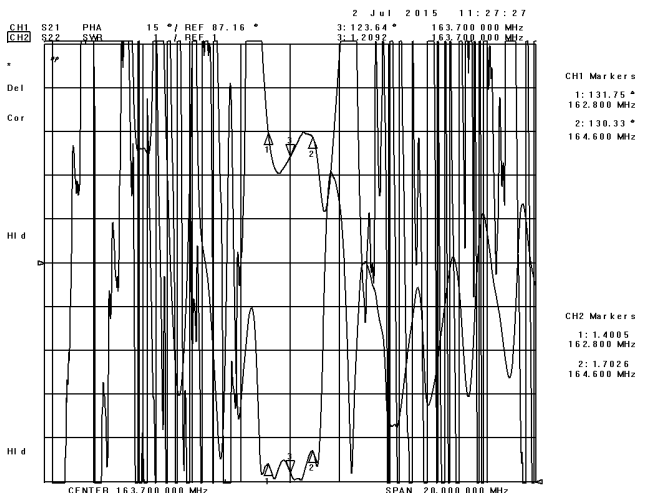

S11 Smith Chart

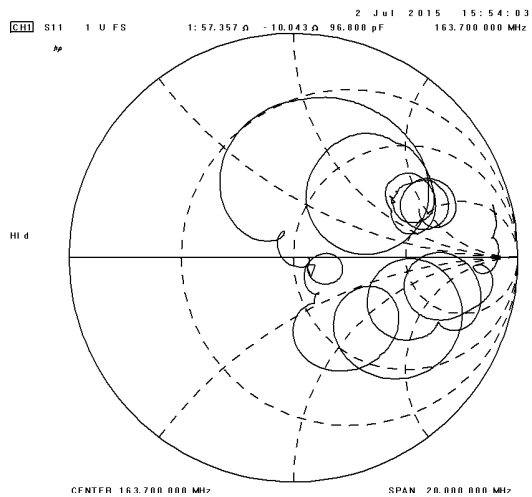

S22 Smith Chart

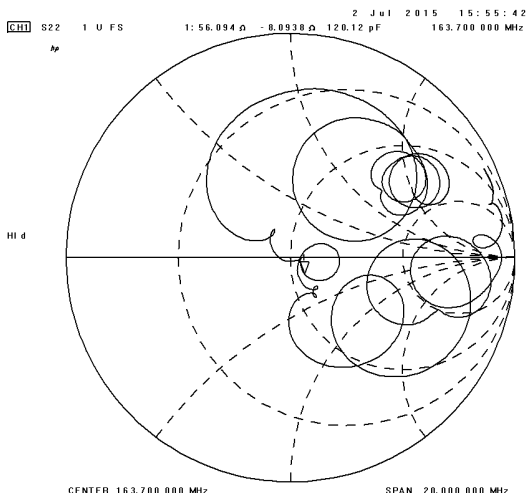

**Reliability (The SAW components shall remain electrical performance after tests)**

| No. | Test item                    | Test condition  |
|-----|------------------------------|---|
| 1   | Temperature Storage          | (1) Temperature: $85^{\circ}\text{C}\pm 2^{\circ}\text{C}$ , Duration: 250h , Recovery time: $2\text{h}\pm 0.5\text{h}$<br>(2) Temperature: $-55^{\circ}\text{C}\pm 3^{\circ}\text{C}$ , Duration: 250h ,Recovery time: $2\text{h}\pm 0.5\text{h}$              |
| 2   | Humidity Test                | Conditions: $60^{\circ}\text{C}\pm 2^{\circ}\text{C}$ , 90~95% RH          Duration: 250h   |
| 3   | Thermal Shock                | Heat cycle conditions: $\text{TA}=-55^{\circ}\text{C}\pm 3^{\circ}\text{C}$ , $\text{TB}=85^{\circ}\text{C}\pm 2^{\circ}\text{C}$ , $t1=t2=30\text{min}$ , Switch time: $\leq 3\text{min}$ , Cycle time: 100 times, Recovery time: $2\text{h}\pm 0.5\text{h}$ . |
| 4   | Vibration Fatigue            | Frequency of vibration: 10~55Hz          Amplitude: 1.5mm<br>Directions: X,Y and Z          Duration: 2h  |
| 5   | Drop Test                    | Cycle time: 10 times          Height: 1.0m  |
| 6   | Solder Ability Test          | Temperature: $245^{\circ}\text{C}\pm 5^{\circ}\text{C}$ Duration: 3.0s--5.0s<br>Depth: DIP--2/3 , SMD--1/5  |
| 7   | Resistance to Soldering Heat | (1)Thickness of PCB:1mm , Solder condition: $260^{\circ}\text{C}\pm 5^{\circ}\text{C}$ , Duration: $10\pm 1\text{s}$<br>(2)Temperature of Soldering Iron: $350^{\circ}\text{C}\pm 10^{\circ}\text{C}$ , Duration: 3~4s ,<br>Recovery time : $2 \pm 0.5\text{h}$ |

**Recommended Reflow Soldering Diagram**

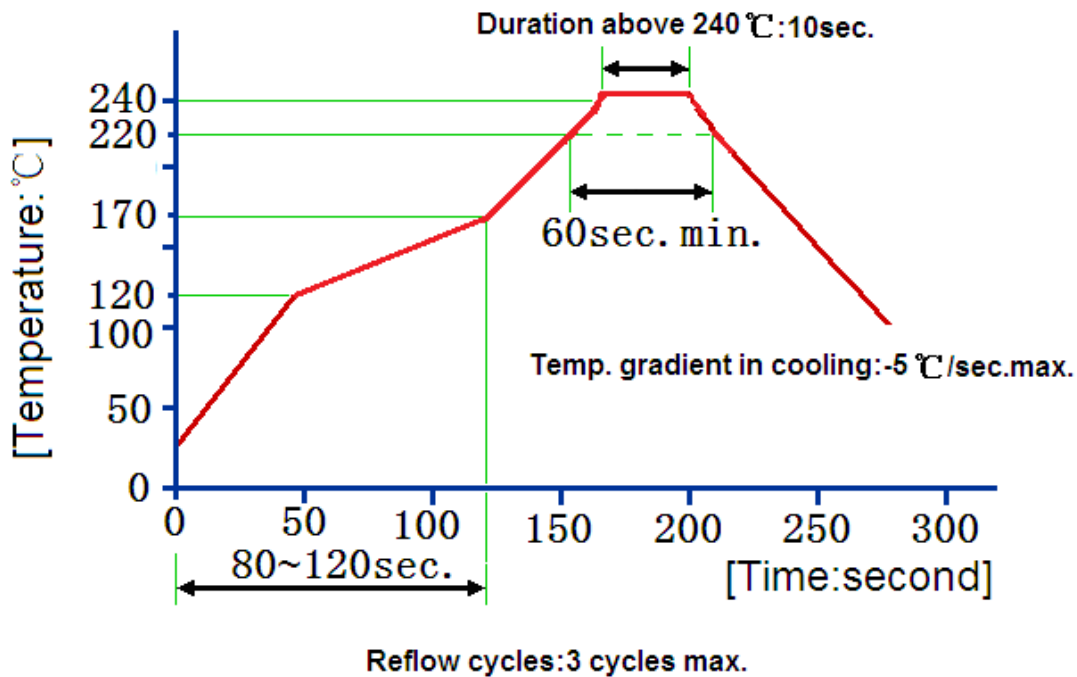

**Notes**

1. As a result of the particularity of inner structure of SAW products, it easy to be breakdown by electrostatic, so we should pay attention to **ESD protect** in the test.
2. **Static voltage** between signal load and ground may cause deterioration and destruction of the component. Please avoid static voltage.
3. **Ultrasonic cleaning** may cause deterioration and destruction of the component. Please avoid ultrasonic cleaning.
4. Only leads of component may **be soldered**. Please avoid soldering another part of component.
5. There is a close relationship between the device's performance and **matching network**. The specifications of this device are based on the test circuit shown above. L and C values may change depending on board layout. Values shown are intended as a guide only.